

Evolved from the rest,
to compete with the best!



FS270-2



**UPGRADED WITH RIDE CONTROL
ELECTRIC AIR SEAT & 360 VIEW CAMERA**

ARTICULATED WHEEL LOADERS



High Power

- Long wheelbase with large breakout force and traction force
- Cummins engines with 70kw (100hp)
- Reinforced drive system
- Bellian 4 Speed Transmission

Comfort & Convenience

- Enlarged cabin space
- Low noise, shock-absorbed and dust-proof cab
- Rear opening engine hood, for easy maintenance
- Pilot Control Joystick
- Premium Lighting Package

Reliability & Durability

- Upgraded hydraulic system
- New design electrical system
- Optimal designed structural components

Safety

- ROPS cab
- External self cleaning disk braking system
- Luxurious operating environment

Energy Saving & Green Initiative

- Low fuel and energy consumption
- Low noise

PH: 1800 566 080

WWW.OLYMPUSLOADERS.COM.AU



FS270-2

NEW FARM SERIES

ARTICULATED WHEEL LOADERS

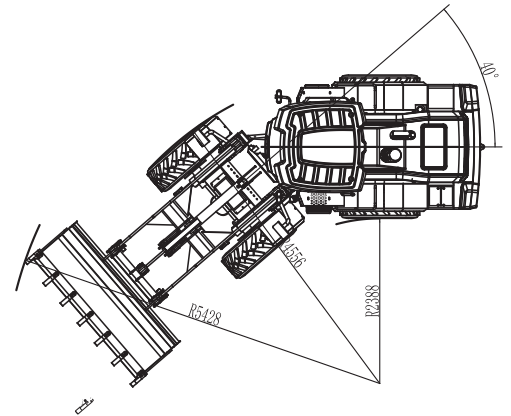
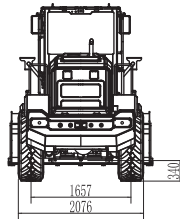
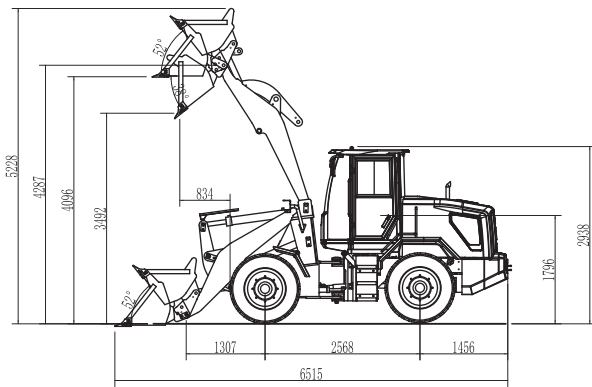

SPECIFICATIONS

Overall Weight	6,800kg
LxWxH (mm)	6200 x 2100 x 2800
Rated Bucket capacity (m ³)	1.2m ³
Rated Load (kg)	2700
Max. Dump Height (mm)	3600
Bucket Indicator	Yes

ENGINE

Model	Cummins
Type	Vertical Inline Water Cooling Four Stroke Turbo Diesel
Rated Power (kw)	70kw (100hp)
Rated Speed (r/min)	2400

TRANSMISSION SYSTEM

Model	Bielian Electronic
Gearbox Type	4 Speed Planetary
Gear Shift	4 Forward, 4 Reverse

MAIN HYDRAULIC SYSTEM

Working Pressure	16mpa
Boom Lifting Time	4.8sec
Fuel Tank Capacity	70Lt

STEERING SYSTEM

Type	Load Sensing Hydraulic Steering
Min Turn Radius (mm)	5000

TYRES

Standard Tyres	16/70-24
----------------	----------

STANDARD BUCKET

Width (mm)	2100
------------	------

ROPS CERTIFIED CABIN

With its high volume Air Conditioner upgrade we have created a much better cooling system for Australia, combined with a sealed cabin it eliminates noise and dust from its working conditions. The sealed cabin has a AM/FM stereo, reversing camera, external fan, suspension seat and tilting steering wheel with warning lights for engine and transmission management.

MODERN CONTROLS

On the dash there is bucket float control activation and all the switches for lights, windscreen washer and accessories, etc. The pilot control joy stick is smooth and light to operate giving sensitive feeling to the operation of the loader's bucket. Auto bucket to dig leveling is also standard. A large rear vision camera is fitted inside the cab for safe, easy reversing.

BRAKING SYSTEM

Olympus models run a dry brake system combining air over hydraulic disc brakes. The disc brakes are self cleaning and are easy maintained with debris covers for protection.

Air operated hand brakes are standard in all models and are located next to the operator's seat.

MULTI PURPOSE TOOL HANDLING

Hydraulic hitches are able to quickly change attachments; from bucket to hayspears to pallet forks within a few seconds. This is achieved from an auxiliary hydraulic function also able to run hydraulic attachments i.e., augers, 4in1 buckets, hydraulic forks etc.



New Spacious Cab
Greater visibility, forward swinging door



Olympus Equipment Sales
 E: sales@olympusloaders.com.au
 P: Simon - 0427 744 049
 2/25-29 Riverland Drive
 Loganholme Q 4129

PH: 1800 566 080

WWW.OLYMPUSLOADERS.COM.AU